

## **BACKBONE**

A different approach to LED wall support

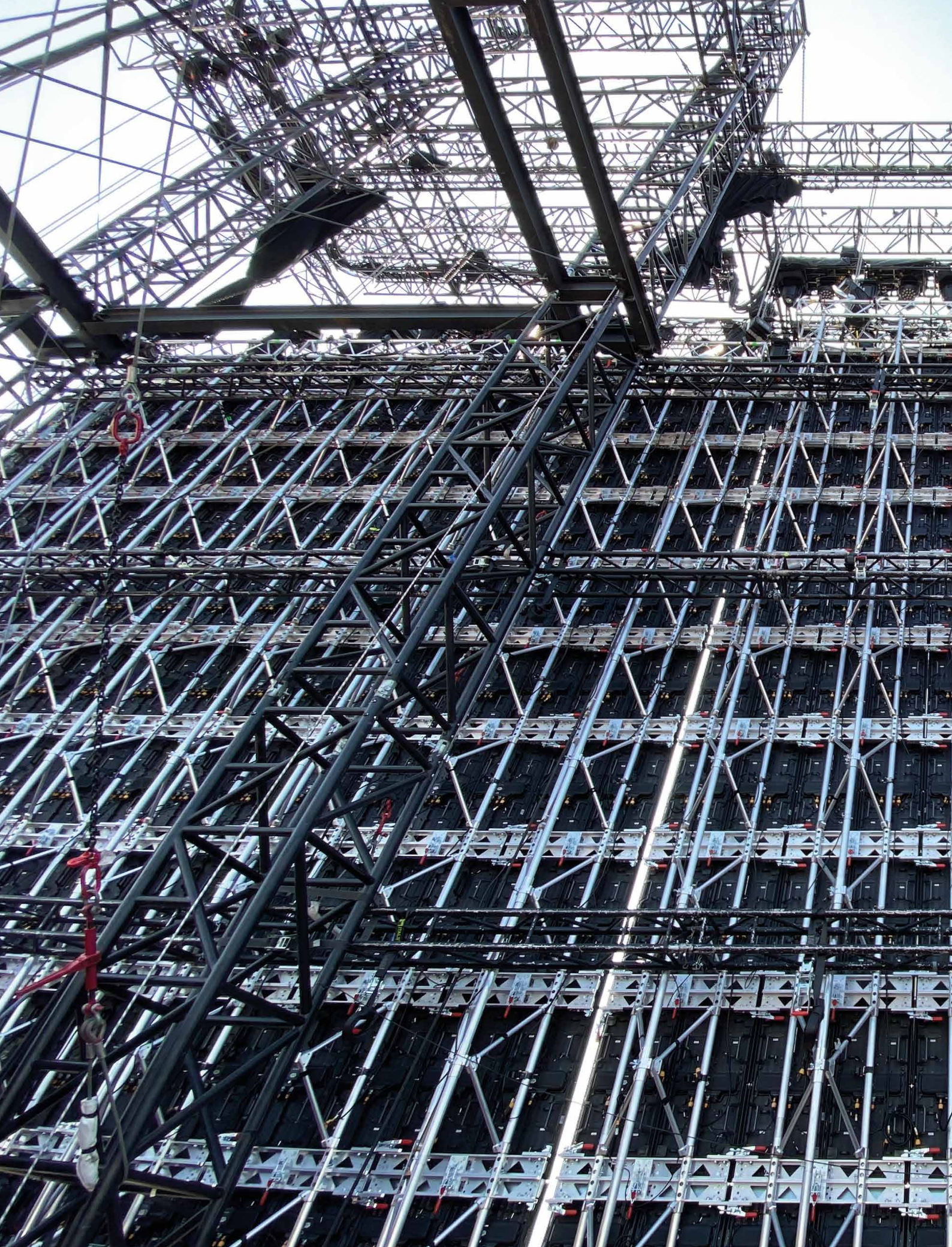

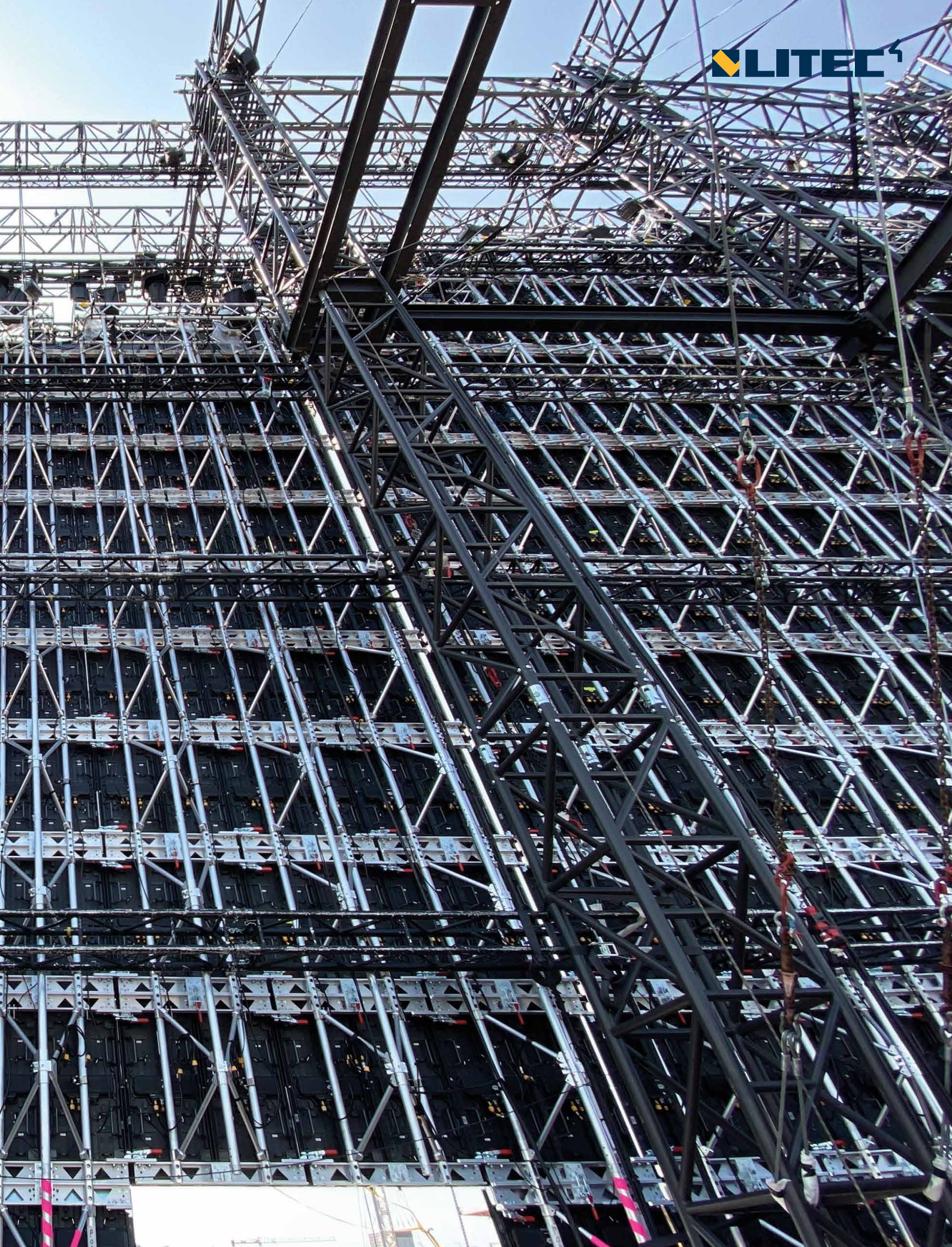

# Backbone Frame Outdoor System

## LED walls, at the center of the scene.

From rock bands to pop stars, from television & film studios to corporate conventions, LED walls have become an indispensable presence for event creators.

The high performance achieved by this technology makes it possible to construct large screens surfaces composed of multiple LED panels.



## Backbone, beyond the scenes.

LITEC Backbone, the solution for building large LED wall screens quickly and securely.

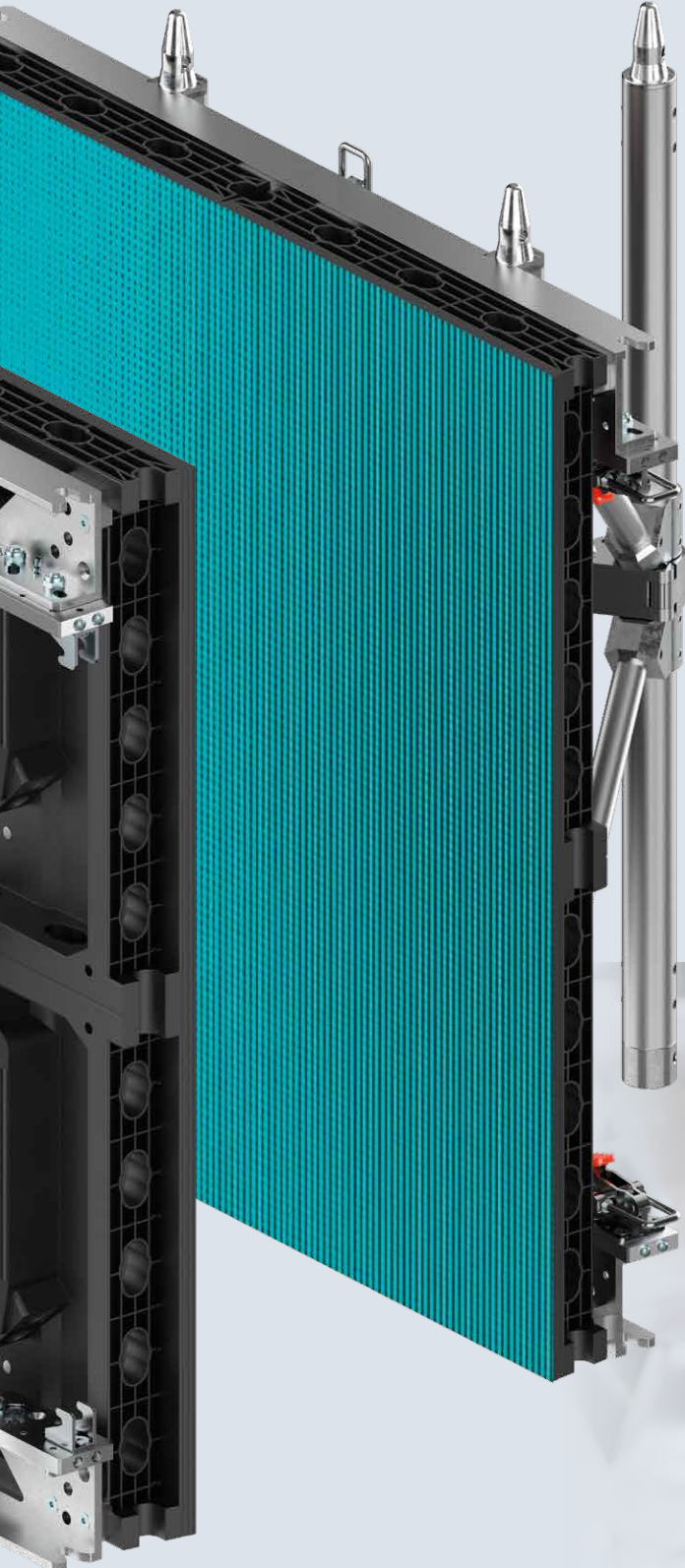

The aluminium reinforcement frame allows for creation of a modular, robust structure that is easy to assemble, disassemble, and move.



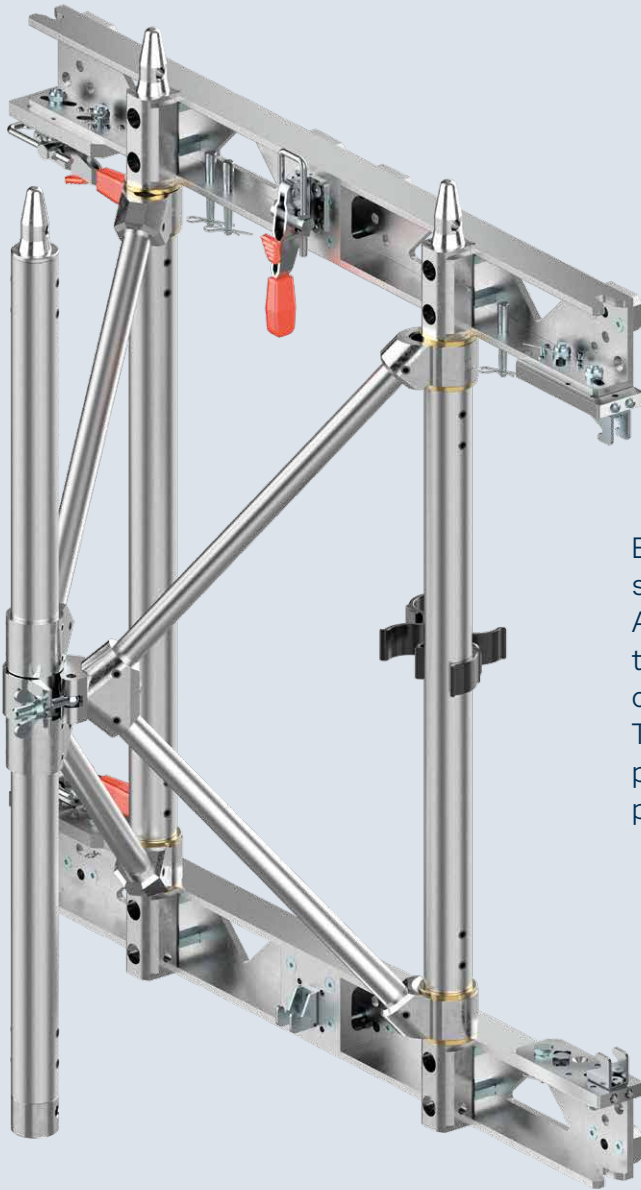

Each frame is made of a sturdy aluminium structure weighing **27.0kg**.  
 A hinge system allows for a transition from the folded transport configuration to the operational position.  
 The coupling between frames is extremely precise, with a tolerance of **0.15mm** for perfect alignment of the LED panels.

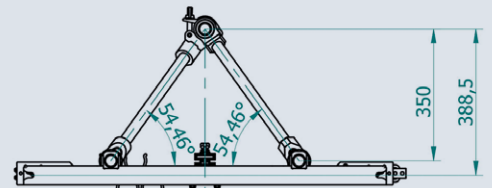
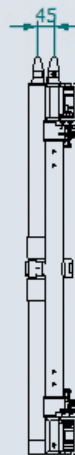
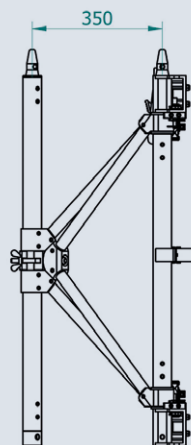
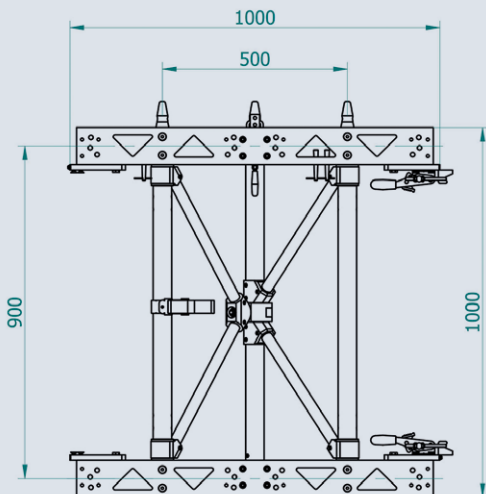

**Operational dimensions**

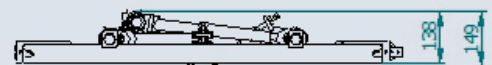

**Folded dimensions**

# Backbone Frame Outdoor System

The Backbone Frame Outdoor system is designed to be hung from a dedicated 40 x 40 heavy-duty anti-torsion aluminium truss specifically “engineered and designed” for this application using special accessories consisting of aluminium clamps to allow easy coupling between the Backbone frames and the truss.

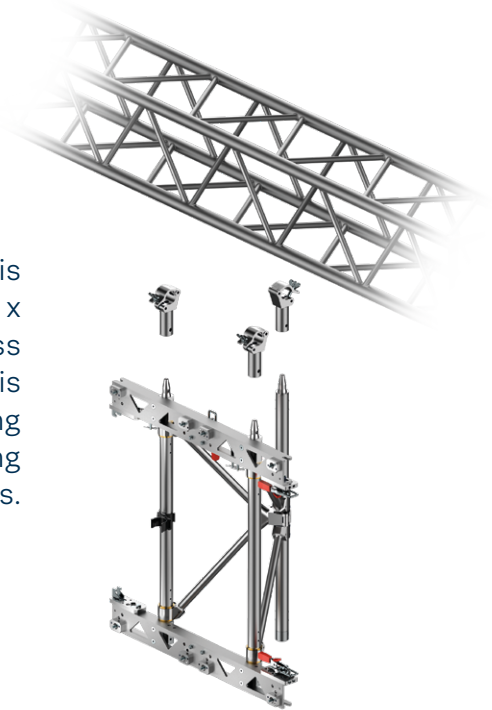
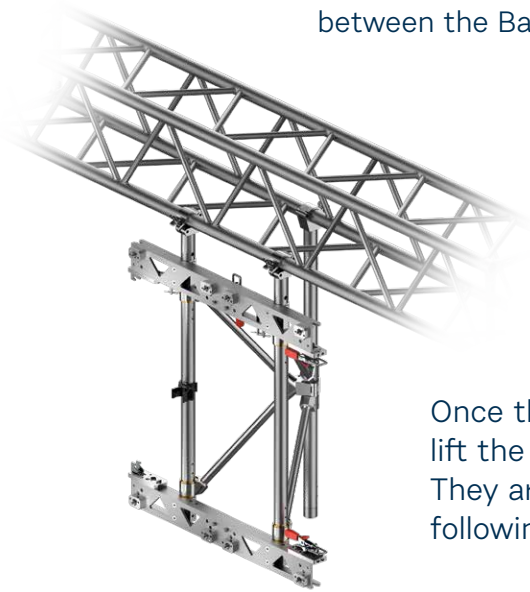

Once the first line of frames is aligned on the ground, lift the truss and add the next line of frames. They are secured together with conical spigots and pins, following the ‘fix and lift’ concept.



# The Slim Option

Where structural conditions permit, you can alternate standard modules with the Slim model. This choice makes the entire structure lighter and simpler to assemble, while also lowering overall costs.

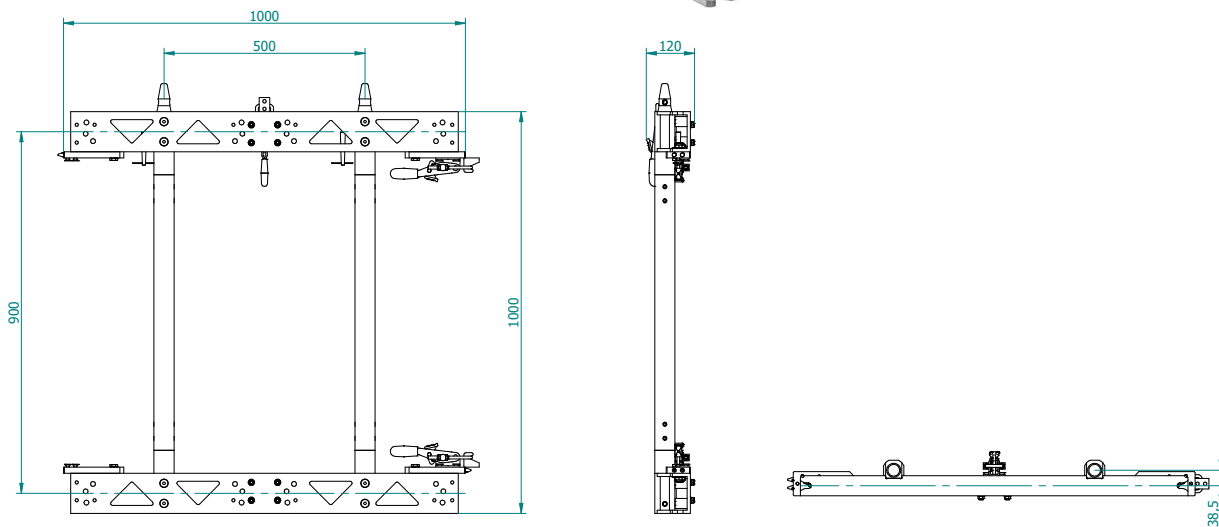





The Slim module connects perfectly with the standard modules, maintaining a consistent and flat surface for the LED panels.



**LITEC** 





### As simple as a fractal

The modularity is derived from the concept of 'fractals.' The basic module expands in every direction to create the LED barrier. Quick lock clamping systems ensure the compactness of the LED panels and perfect alignment between surfaces.

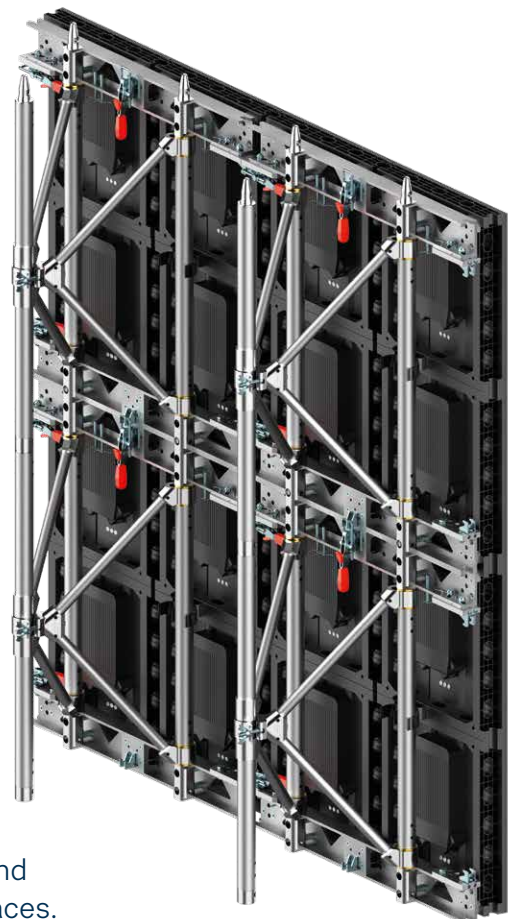
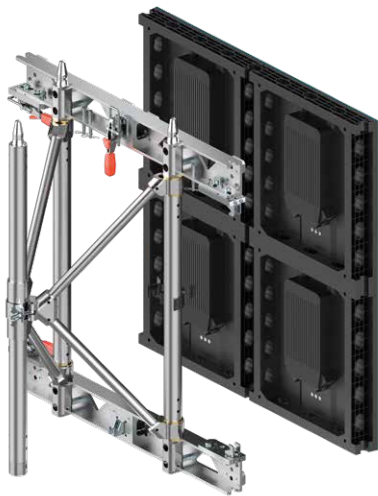

It's a system that came out of the need of a robust and modular structure allowing to build large vertical surfaces. These surfaces, due to their heights and dimensions, would otherwise require scaffolding in the backstage area, resulting in significant costs and time. With the Backbone Frame, light designers are now freer to pursue their dreams.

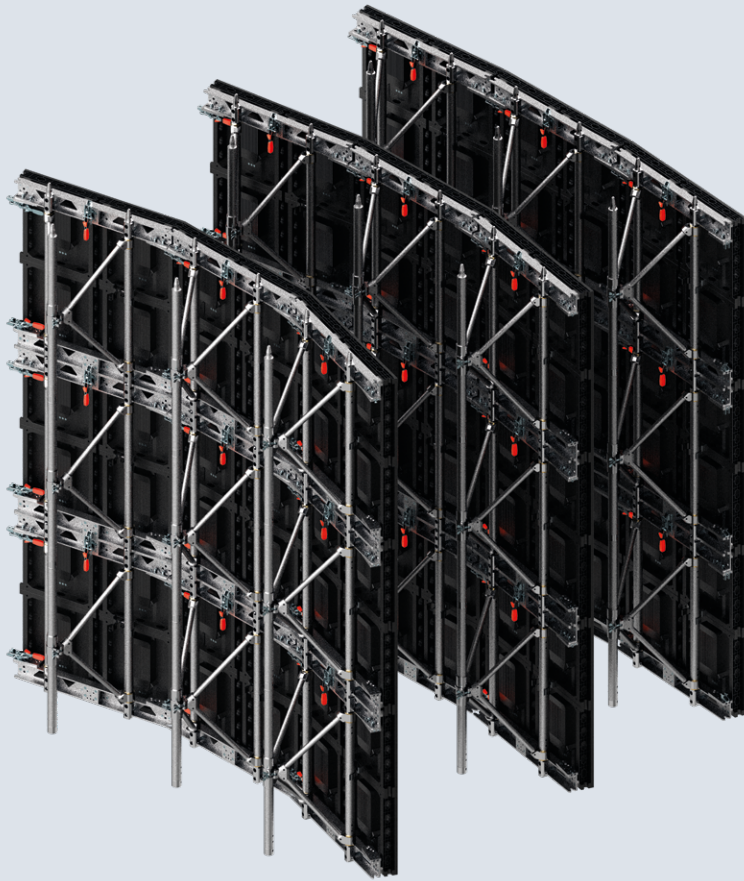

### Concave and convex

Concave or convex: The Backbone frames offer adjustable curvatures at angles of 2.5°, 5.0°, and 7.5°, in both positive and negative directions. By tweaking the position of the connecting screws, you can effortlessly create undulating and curved effects.

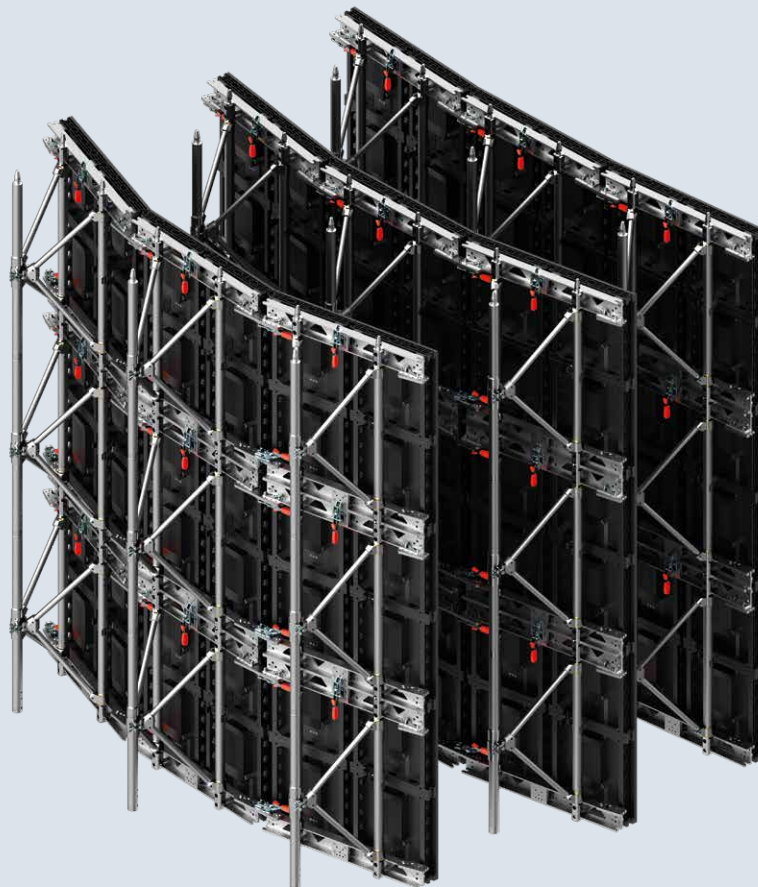

# Designed for live tours

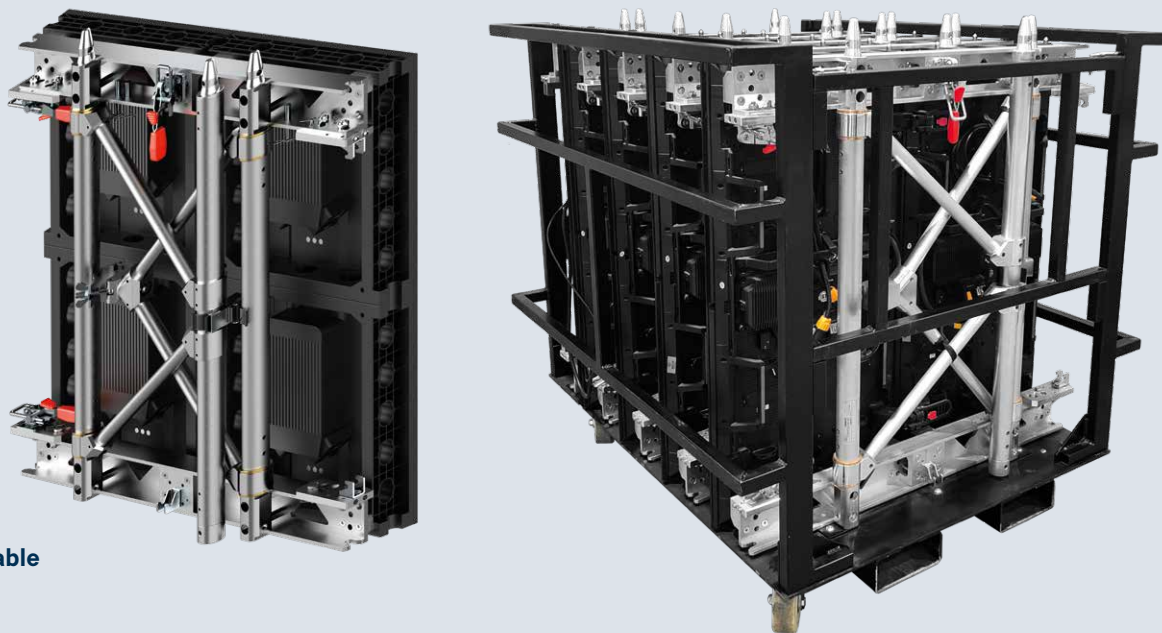

**Easily foldable**

The pre wiring of 4 LED 50x50cm panels for each Backbone module ensures efficiency and time saving during installation.

Each 1x1 metre frame can be compacted to a thickness of 20cm (depending on LED panel used) and can be stored and transported on carts.



# Any shape

## Flexibility in use with maximum operational safety.

Virtually, there are no limits in constructing a wall of LED modules. The modularity of the system and its intrinsic robustness make large scale applications possible, with an excellent wind resistance and the freedom to execute formats of any shape.



Scan this QR Code  
to watch the video

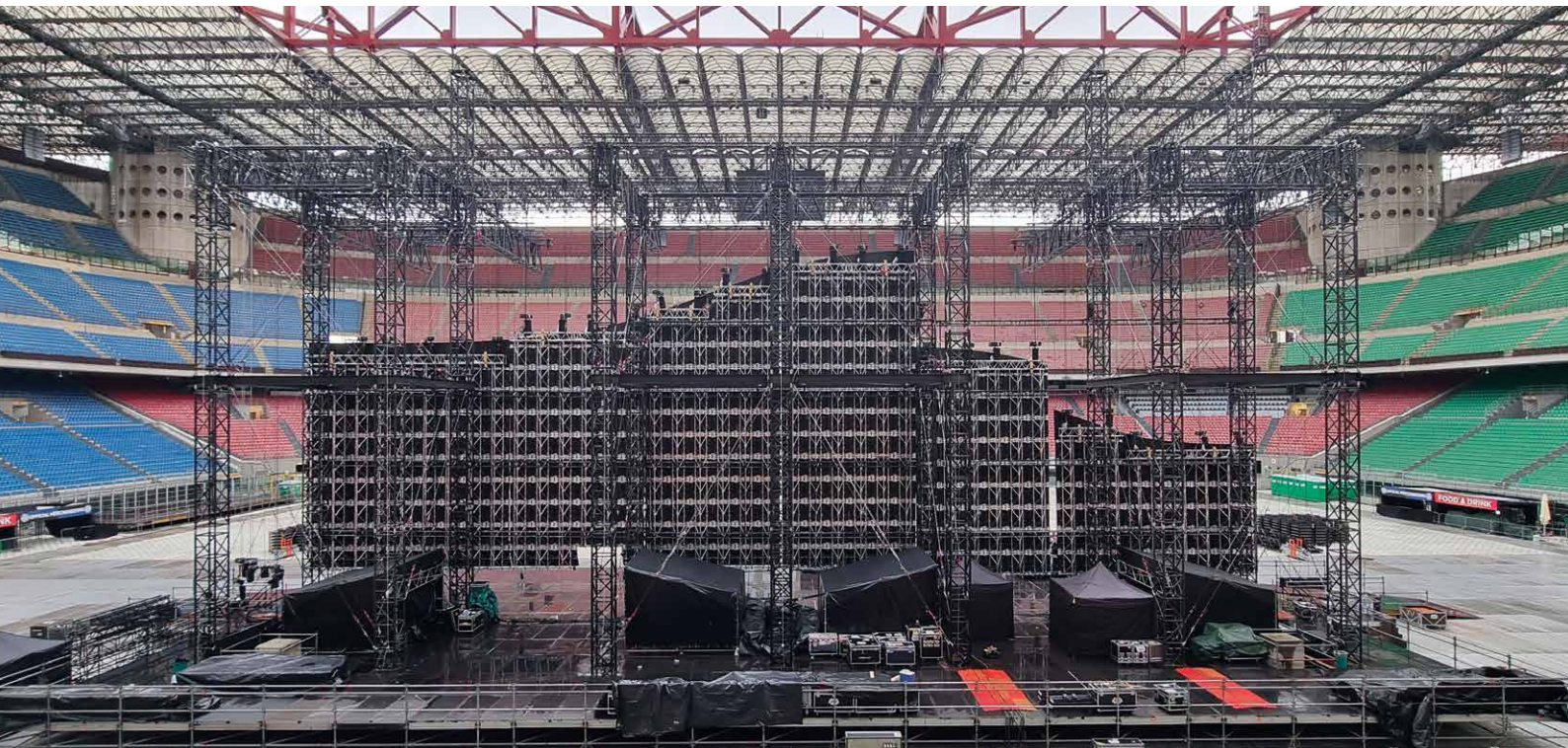
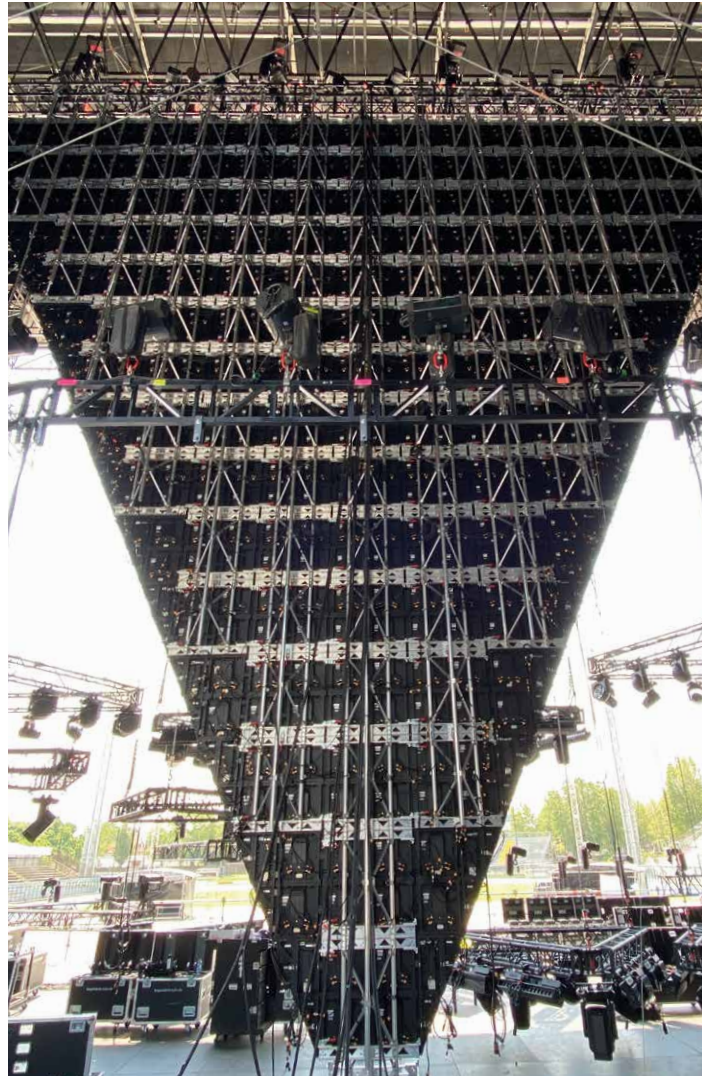

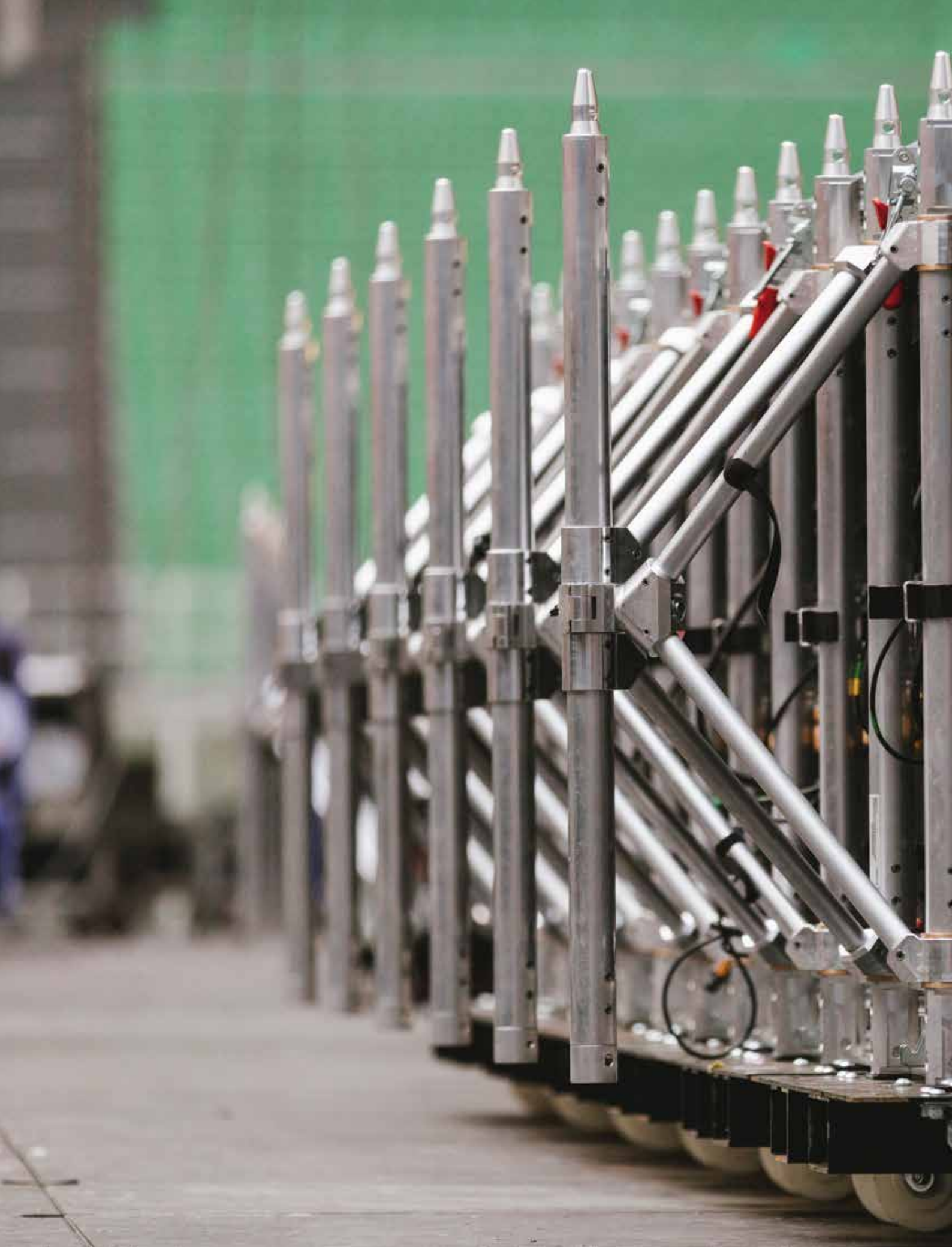





**The spirit of innovation that has distinguished LITEC since its inception continues year after year.**

**Innovating in solutions designed to support tailor made projects for our clients, innovating in creation of entirely new product lines.**

**Solutions that arise from the constant collaboration between our technical staff and the most discerning users to create new ambitious products.**

**LITEC<sup>4</sup>**

# Backbone Frame Indoor System

With just four custom-designed modules, you can convert your trusses into a powerful support system for LED panels. Add a few more modules and check your inventory-you'll quickly have a professional modular system ready to go.

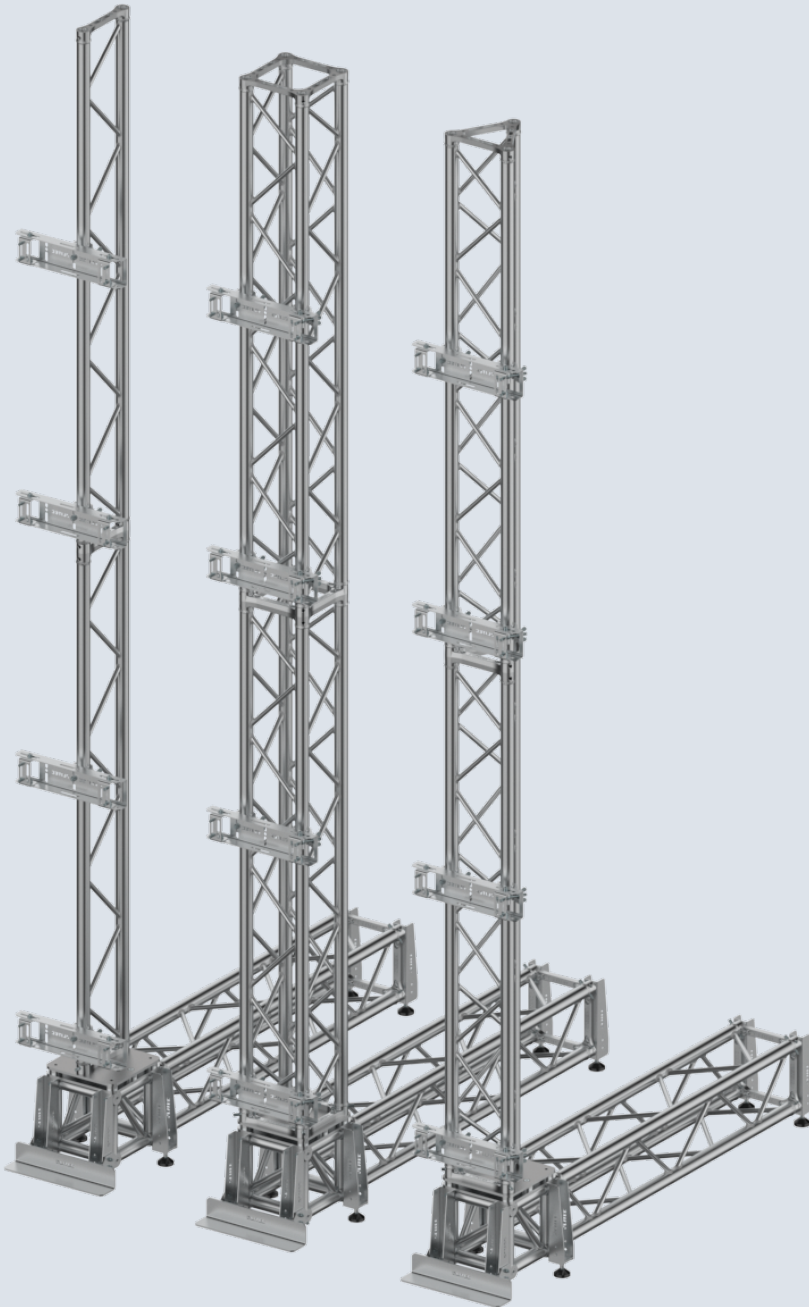

LT LW-K006  
**Universal bracket with truss clamps  
for the column in QX30SA/TX30SA/FX30SA**

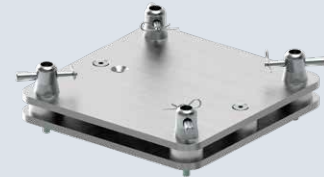

LT FP30QU30K02  
**Mounting plate for attaching the column  
in QX30SA/TX30SA/FX30SA**



LT LW-AF001  
**Sturdy adjustable foot**



LT LW-LS001  
**LED panel support shelf**

In addition to large outdoor structures, there is always high demand for simple and reliable solutions to set up LED wall inside fair stands, conference halls, shops, and, of course, entertainment events.

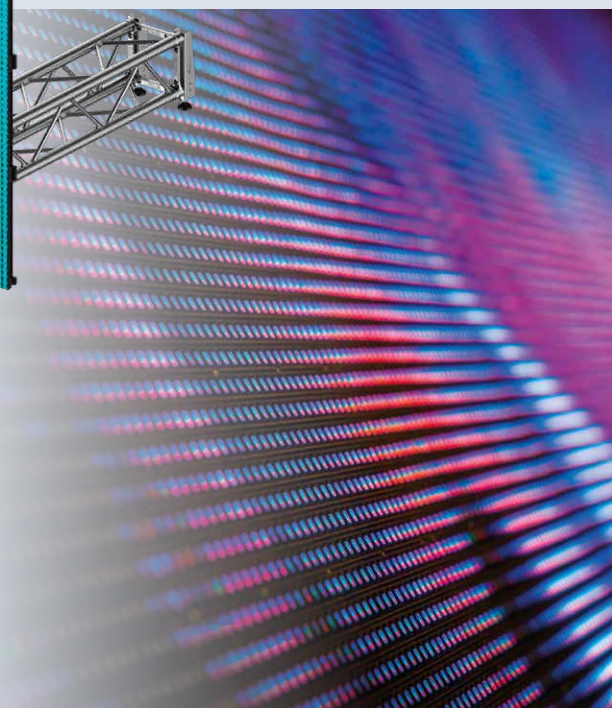
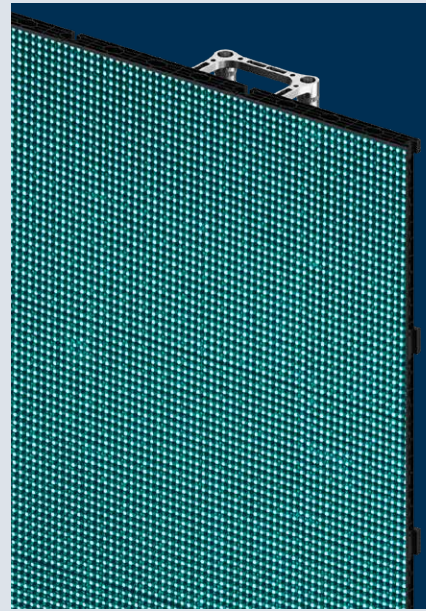

# Modular Solutions

The range of standard products in the LITEC Truss catalogue is designed to meet these needs. By simply adding interface modules with clamps and a support base between the trusses and the LED panels, you can create a versatile support system.

The heights allowed by these solutions vary depending on the trusses used and the type of LED panels. Please contact us for more information.

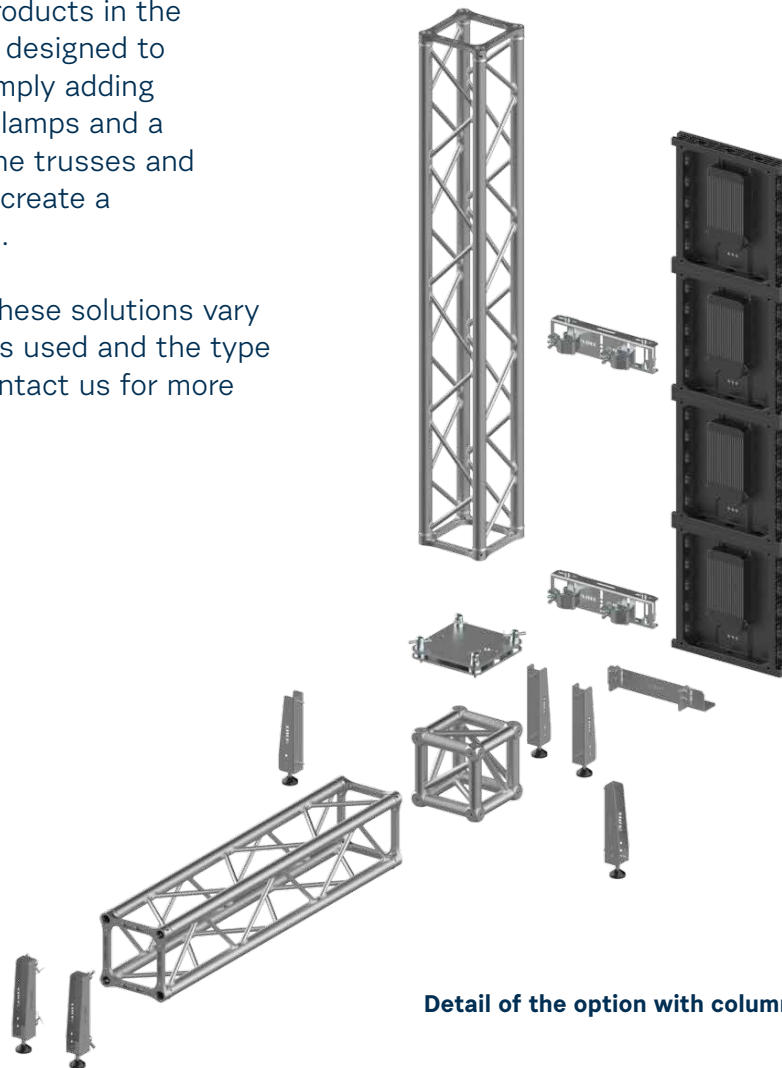

Detail of the option with column in QX30SA

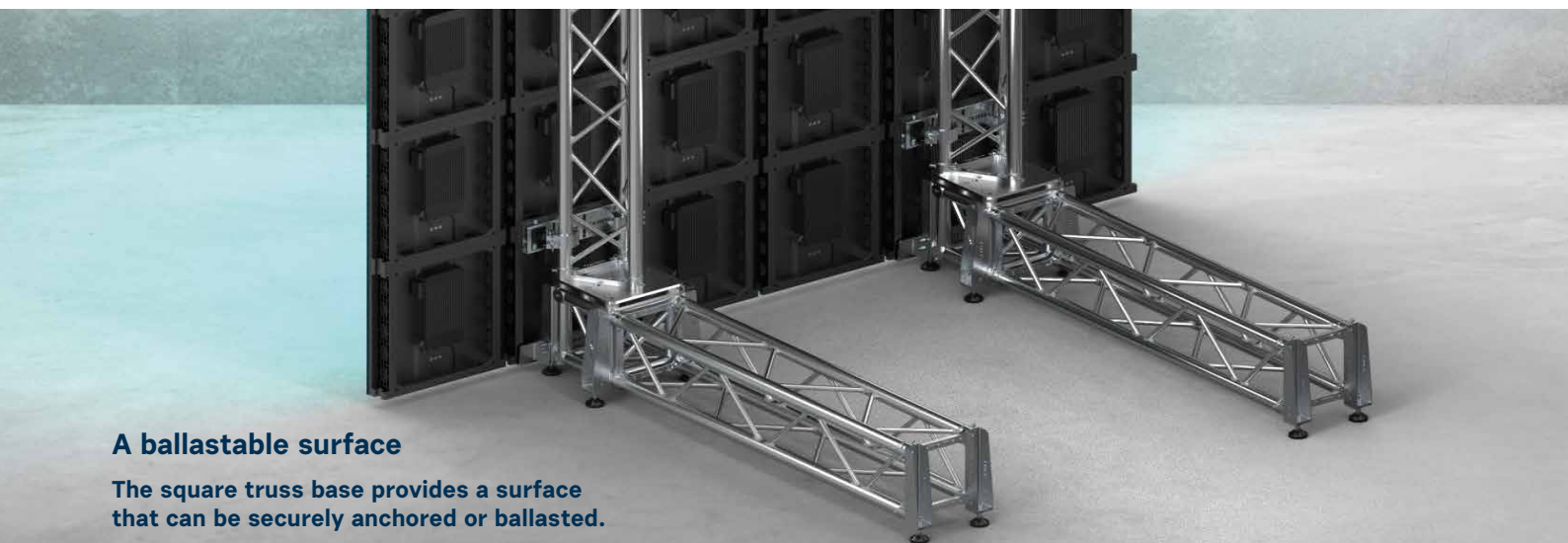

## A ballastable surface

The square truss base provides a surface that can be securely anchored or ballasted.

We have three distinct options, each varying based on the type of truss used.

The accessories are designed to fit the vertical sections of the flat FX30SA truss, the triangular TX30SA truss, and the commonly used square QX30SA truss.

For each option, the ground support truss must be the QX30SA model.

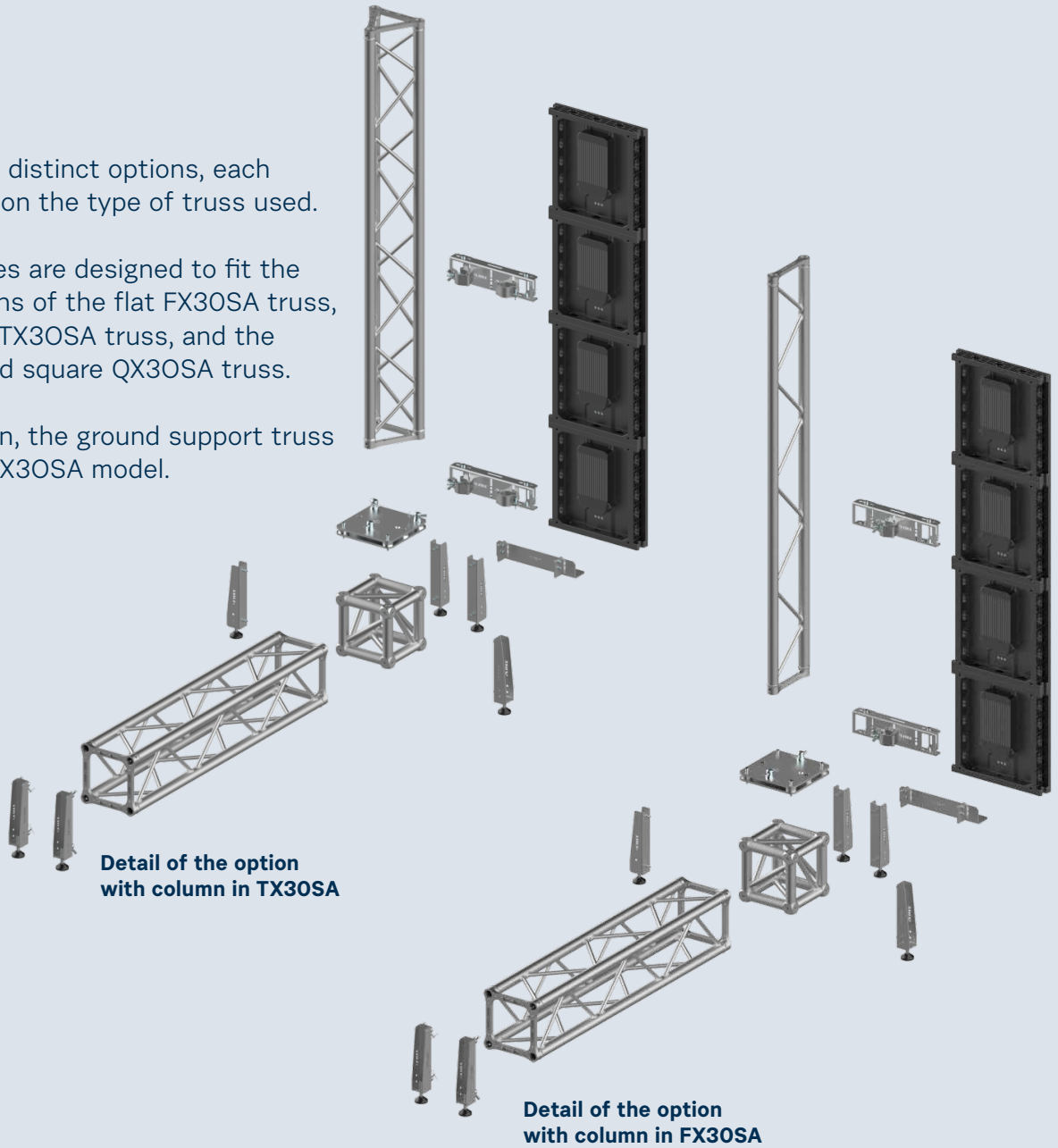

**Detail of the option with column in TX30SA**

**Detail of the option with column in FX30SA**

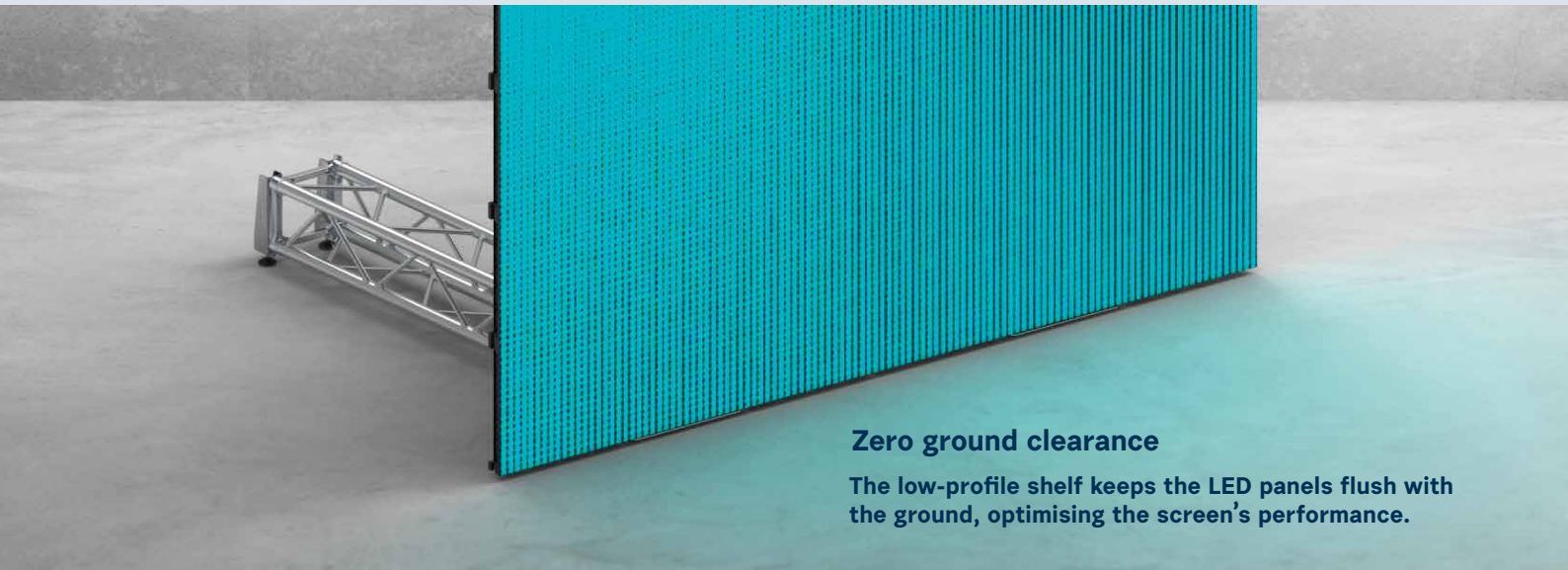

**Zero ground clearance**

The low-profile shelf keeps the LED panels flush with the ground, optimising the screen's performance.

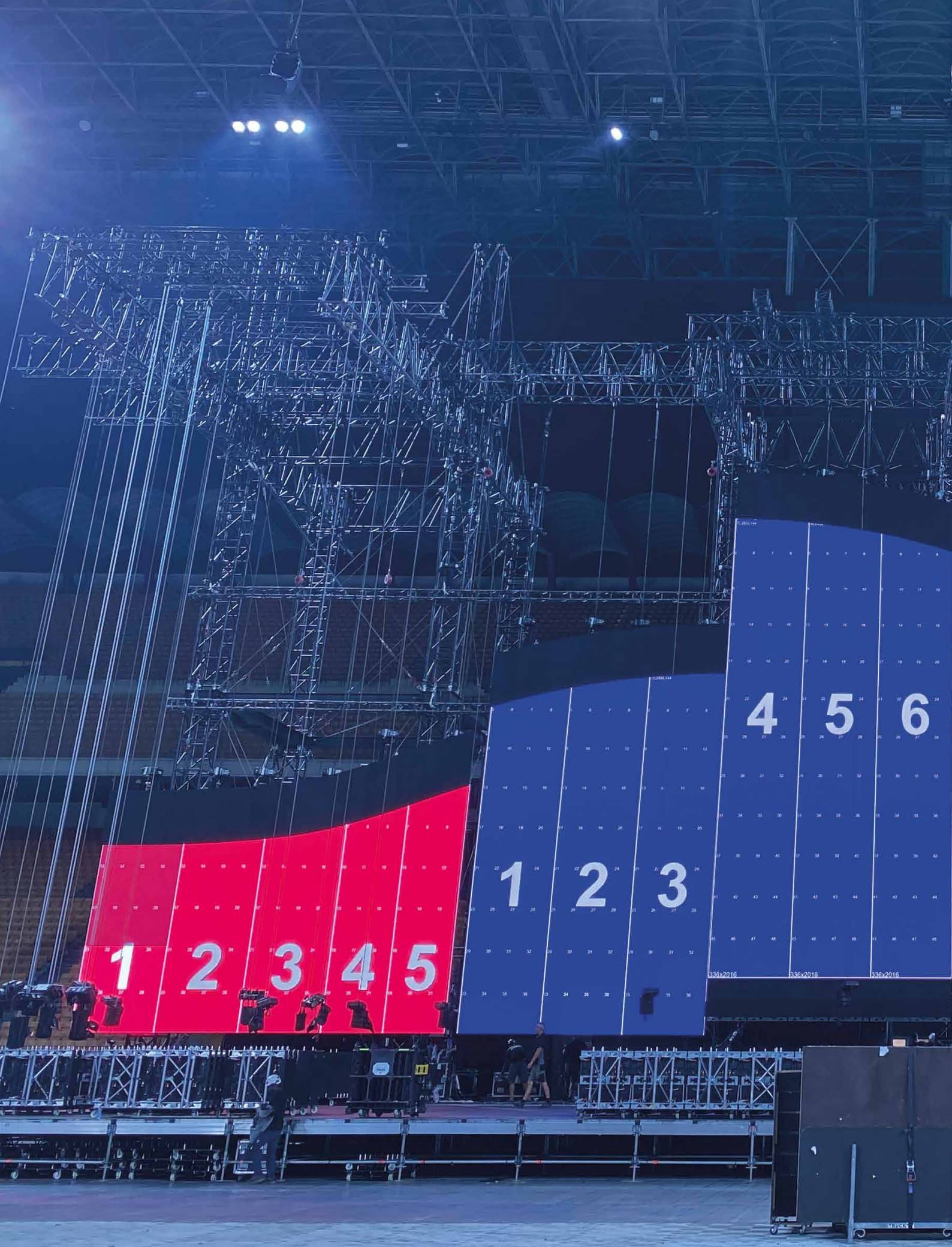

1 2 3 4 5

1 2 3

4 5 6

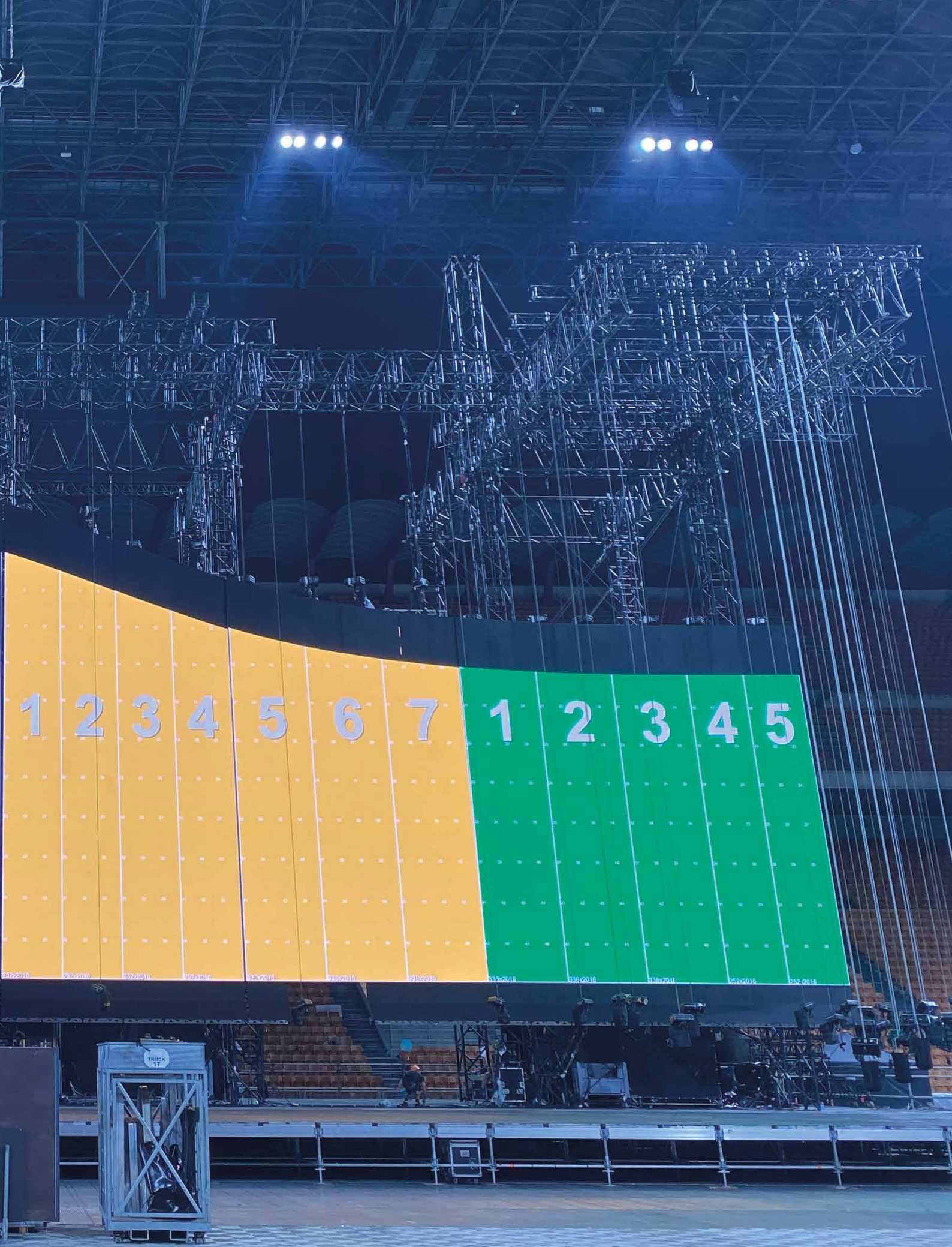

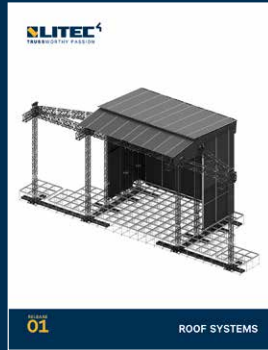
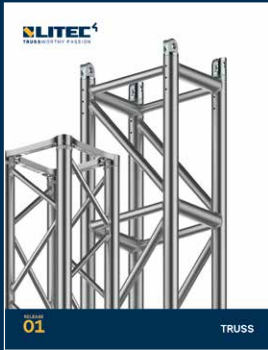

**Area Four Industries Italia S.r.l.**

Via Martin Luther King 70, 31032  
Casale sul Sile (TV), Italy

T +39 0422 997 300

[www.litectruss.com](http://www.litectruss.com)  
[www.litectruss.it](http://www.litectruss.it)

[info@litectruss.com](mailto:info@litectruss.com)



Follow us: [@litectrussing](https://www.instagram.com/litectrussing)

